

[Home](#) ■ [HUBER Report](#) ■ [HUBER SE supplies ThermWin® system for heating and cooling with wastewater at a museum](#)

HUBER SE supplies ThermWin® system for heating and cooling with wastewater at a museum



A house of the future for the history of the present in the city of Regensburg

In the city of Regensburg in the Upper Palatinate, an administrative district in the Northeast of Bavaria, the new museum of Bavarian history is currently under construction.

The worldwide successful environmental company HUBER SE based in Berching is involved in this building project as the supplier of a sustainable, innovative system solution which makes it possible to heat and cool the museum building with energy from wastewater. It is a prestigious project which is of special importance for HUBER, not only due to its proximity to the company's headquarters.

Bavaria and its myths are legendary, the Free State of Bavaria a success model and its cultural landscapes are much admired. Bavaria has a variety of museums for the most varied issues, however not yet one for its own recent history. This gap will be closed by 2018, the year in which the Free State of Bavaria will be celebrating its 100th anniversary. In his government declaration of December 2008, Bavarian Prime Minister Horst Seehofer announced the plans for the new museum.

The focus of the new showplace will be on the people who have been living in Bavaria, all tribes, including those immigrated from afar who have found their new home here. Everyone is invited to participate in building the museum by contributing personal stories and memorabilia. The museum tells the story how the State of Bavaria has become what it is today and what makes it so very special.

For a long time already, Bavaria has counted on combining the past and the present, the old & proven and the new & innovative. Innovations 'made in Bavaria' like HUBER's ThermWin® System give proof of the capacity of Bavaria's economy and especially that of its medium-sized enterprises.

A logistic challenge

More than 20 construction companies, many of them are local companies or from Bavaria, are involved in this large-scale project – one of the largest construction sites in Regensburg. "The extremely limited space in the middle of the historic city centre is a very special challenge", explained State Minister Joachim Herrmann. All parties involved in the project are faced with a tight schedule until project completion in the anniversary year 2018 when Bavaria can celebrate the kingdom's 200-year constitution and the 100-year anniversary of the State of Bavaria.



The erection of the museum precedes

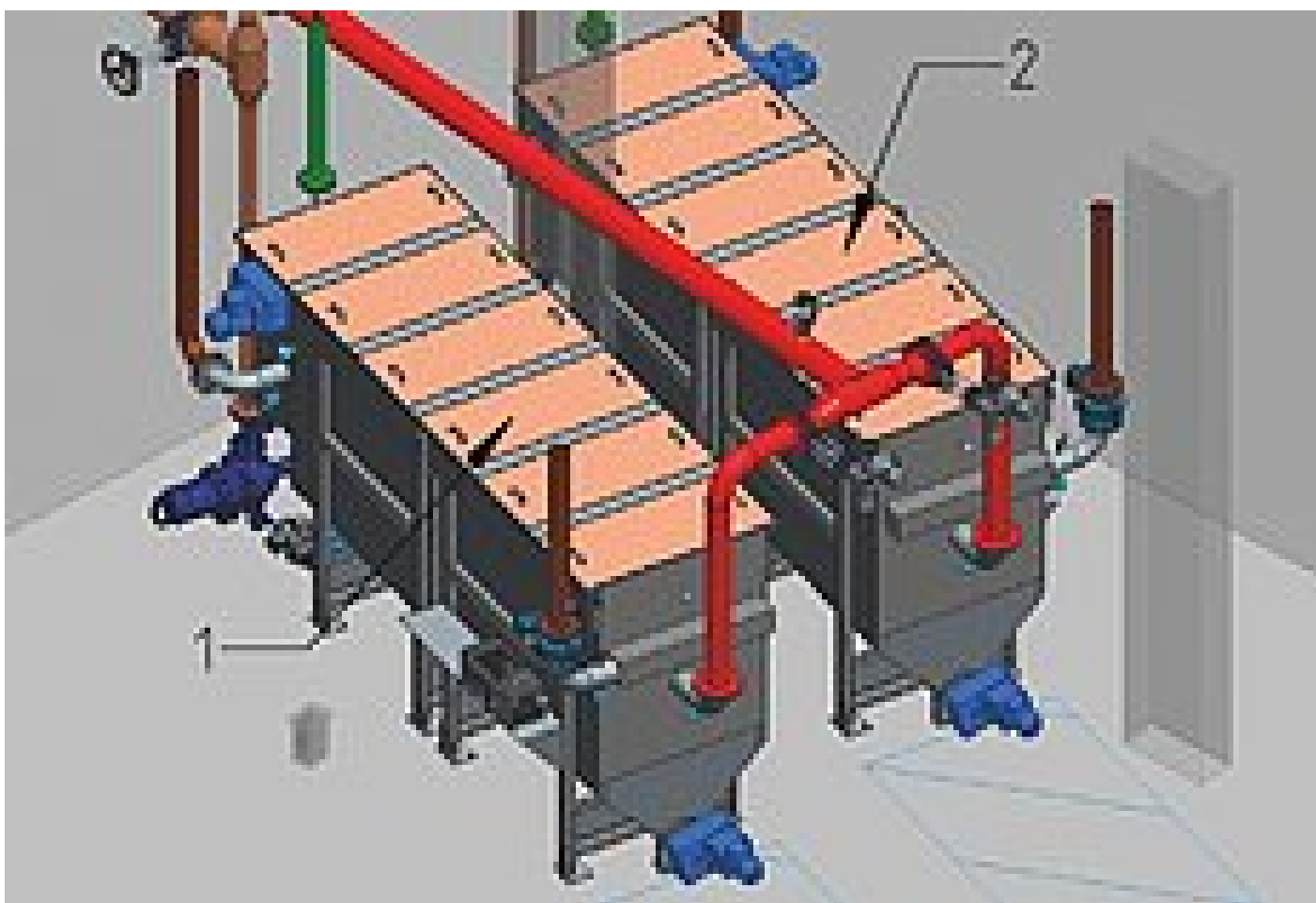

2 x HUBER Heat Exchanger RoWin units, size 8

HUBER ThermWin® System supplies clean energy for heating and cooling the museum

A special structure was built to enable the wastewater to be extracted from the sewer. Now, up to 70 l wastewater per second can be extracted. The coarse solids are removed from the wastewater in a HUBER Pumping Stations Screen ROTAMAT® RoK4. The preclarified water is pumped to two HUBER Heat Exchanger RoWin units.

Due to the heat exchanger operation in combination with the heat pump, either heat is extracted from the wastewater and introduced into the building (for heating) or heat is extracted from the building and introduced into the wastewater (for cooling). The slightly cooled

down or heated wastewater is finally returned to the sewer together with the previously separated solids.

HUBER supplies for the museum of Bavarian history a ThermWin® system with a heat output of 2 x 280 kW and a cooling capacity of 2 x 500 kW. The HUBER Heat Exchanger RoWin units are self-cleaning systems with very low maintenance requirements. For easy positioning of the equipment inside the building, the heat exchangers will be delivered as flanged units and assembled on site.

The HUBER ThermWin® System is part of the museum's innovative concept for the use of the energetic potential of renewable energy sources. Such an energy source is also the wastewater in our cities. With its ThermWin System HUBER has developed a solution that reliably provides access to the energy resource wastewater.

Related Products:

- [HUBER Heat Exchanger RoWin](#)

Related Solutions:

- [Wastewater Heat recovery: HUBER Solutions for Local and Short Loops](#)
- [HUBER Solution for Heat Recovery from Sewers \(ThermWin\)](#)

Huber Technology Middle East (FZE)
P.O. Box: 120137
Plot J2-08
Sharjah International Free Zone
United Arab Emirates

Tel.: +971 6 5574059
Fax: +971 6 5574069

Email: info@huberme.com
Internet: www.huberme.com

Member of the HUBER group:
www.huber.de
