

[Home](#) ■ [HUBER Report](#) ■ [RoWin for a win-win: Various application possibilities for heat recovery](#)

RoWin for a win-win: Various application possibilities for heat recovery

„There is one thing that is for sure: The age of cheap energy is over!“

Nobuo Tanaka, executive director of IEA (International Energy Agency)

He describes with few words why it is becoming increasingly important to recover used energy. The below examples of projects that use wastewater and process water heat show how energy recovery can successfully be realised in practice.



Fig. 1: Example of an application with filtrate water

Energy recovery from vapour water

In sewage treatment plants vapour water is generated during the sludge dewatering process and is also present in the wash water of the exhaust air treatment systems of sewage sludge drying plants. We have already realised two projects (ARA Bern in Switzerland and Lindenschmidt KG in Germany) where, with the use of the HUBER RoWin Heat Exchanger, considerable amounts of energy are successfully recovered from such kind of wastewater with approx. 1% DS through cooling.

Figure 1 shows an example layout of such an application for a sewage treatment plant size of 100,000 PE. The example shows that more than 50 kW heat can be extracted from the vapours and passed on to a heat pump that produces approx. 750 kW heat from these vapours which are available to be used to heat digester sludge and/or a building area of up to 25,000 m² (= 3.5 times the size of a soccer field) or for external district heat supply. The investment pays off after a short time and the significantly improved carbon footprint additionally justifies the investment costs.

Another positive side effect is that precipitation takes place while the wastewater is cooled so that annoying growth in pipelines is prevented. The generated solids can be removed from the heat exchanger and disposed of separately.

HUBER RoWin Heat Exchanger for direct preheating of process water in a hospital

A flow of high-temperature wastewater is passed through the heat exchanger through which fresh drinking water flows from the other side. In this case, it is not necessary to use a heat pump as the heat already has a high temperature level. In the university hospital "Klinikum rechts der Isar" in Munich heat is directly recovered from the surgical instruments washers and returned to the washers on the fresh water side (see fig. 2). Heat recovery in such a small circuit offers two advantages: First, the systems used are relatively simple in most cases and therefore cheap to implement. Second, the time offset from when the warm wastewater is generated to when fresh water is needed is short. The unique buffer function combined with the patented cleaning of the HUBER RoWin Heat Exchanger makes this application so efficient.

RoWin for a win-win

The company Lindenschmidt KG in Kreuztal, Germany, is a disposal company for problematic oil-containing materials. Biological degradation of these materials leads to a strong rise of the wastewater temperature in the aeration tank so that cooling is welcome.

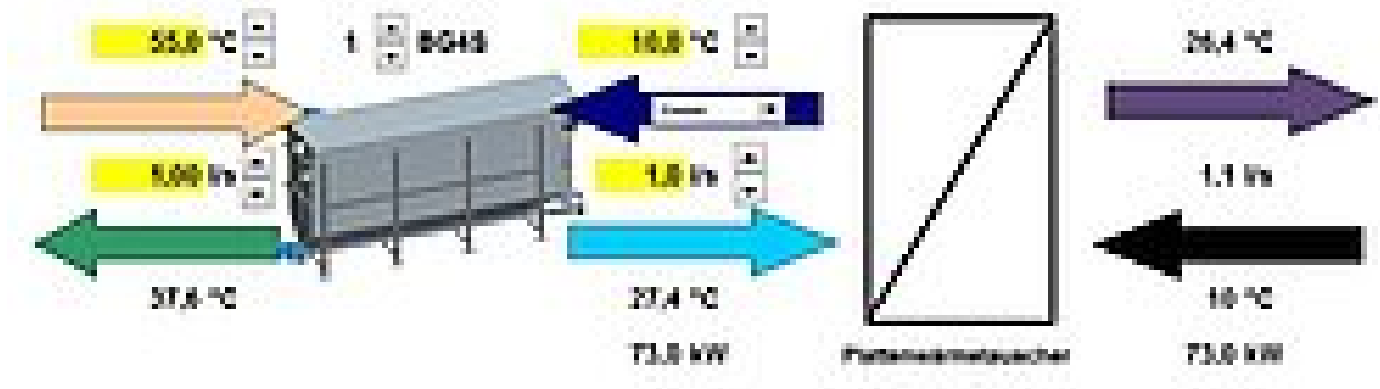

Fig. 2: Example: University hospital "Klinikum rechts der Isar", Munich

With the use of the HUBER RoWin Heat Exchanger energy can be extracted from the waster in the bio-system and directly passed on to the waste oil storage tank. This solves two problems at a time: First, the temperature in the bio-system is optimised. Second, fossil energy carriers that would be required to heat the waste oil storage tanks can be saved.

A variety of application possibilities in various industries

The basic idea of these economical applications for heat recovery from polluted media can also be transferred to for example food industries (preheating of feed water for vapour generation), paper mills as well as disposal companies and other producing industries that generate warm/hot wastewater.

Related Products:

- [HUBER Heat Exchanger RoWin](#)

Related Solutions:

- [Wastewater Heat recovery: HUBER Solutions for Local and Short Loops](#)
- [HUBER Solutions for Wastewater Heat Recovery from Sewers](#)

Huber Technology Middle East (FZE)
P.O. Box: 120137
Plot J2-08
Sharjah International Free Zone
United Arab Emirates

Tel.: +971 6 5574059
Fax: +971 6 5574069

Email: info@huberme.com
Internet: www.huberme.com

Member of the HUBER group:
www.huber.de